



# MINIHOPPER

## F1PRO-1012/1024



Technical Manual (Preliminary)

12/2004

---

This document is confidential by law and it is FORBIDDEN to reproduce or transmit it to any third party without prior permission from Hopper

The descriptions and illustrations herein contained are not binding; Hopper reserves the right to carry out any modification held to be necessary.

The machines may be updates and may, therefore, vary in some details from those shown; this in no way prejudices the text contained in this TECHNICAL MANUAL

---

## CONTENTS

### Chapter 1 - GENERAL INFORMATION

- 1.1 Description
- 1.2 Mani features
  - 1.2.1 Coin exit (single connection)
  - 1.2.2 Twin Connection feature
  - 1.2.3 Electric stirrer
  - 1.2.4 Standard ccTalk
  - 1.2.5 Dejamming Feature
- 1.3 Safety
- 1.4 Installation

### Chapter 2 – MECHANICAL DESCRIPTION

- 2.1 General Description
- 2.2 Exploded Diagram

### Chapter 3 – ELECTRICAL DESCRIPTION

- 3.1 General Description
- 3.2 Power Supply
- 3.3 Operating Modes
- 3.4 Optical Sensors
- 3.5 LED Indicators
- 3.6 Level Sense Plates

### Chapter 4 – ELECTRICAL SPECIFICATION

- 4.1 Input/Output Signals
- 4.2 Flat connector with 10-pin
- 4.3 In line connectror with 10-pin
- 4.4 Address Selection

### Chapter 5 – TECHNICAL SPECIFICATION

- 5.1 Coin Sizes
- 5.2 Motor and Logic Supply
- 5.3 Overall Dimensions

## 1 - GENERAL INFORMATION

### 1.1 DESCRIPTION

The MINIHOPPER is a new and versatile coin and token dispenser that can be used in a wide range of different applications like vending machines and gaming.

### 1.2 MAIN FEATURES

#### 1.2.1 COIN EXIT (SINGLE CONNECTION)

Coins exit is located in the up right position (Fig.1).

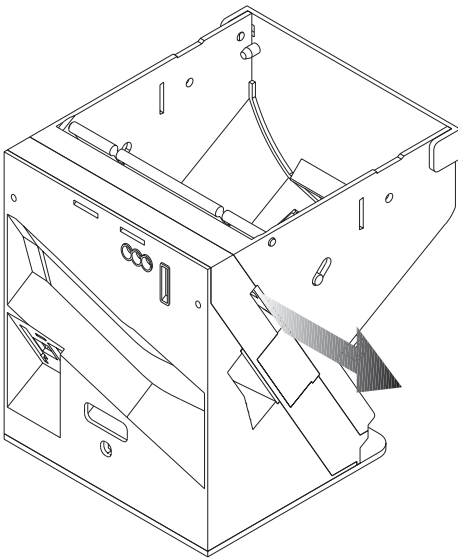

Figure 1: Single Connection

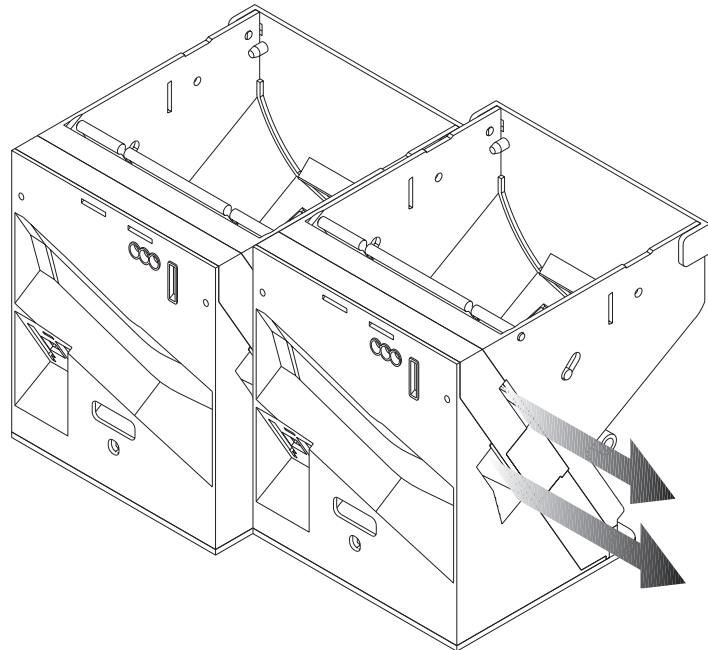

Figure 2: Twin Connection

#### 1.2.2 TWIN CONNECTION FEATURE

It is possible to place two MINIHOPPER side by side in the so called TWIN CONNECTION (Fig. 2) and to obtain two different functioning configurations, suitable for different uses.

It is possible to select a single exit in which diverting coin of both MINIHOPPER or to select two near different exits for coin with different values.

#### 1.2.3 ELECTRIC AND MECHANICAL STIRRER

The MINIHOPPER can move coins weight through both a mechanical stirrer and a vibrating movement that the motor performs periodically (electric stirrer).

---

#### **1.2.4 STANDARD ccTALK**

The MINIHOPPER F1PRO-1012/1024 works using the communication standard ccTalk. Its address can be easily selected via hardware through three inputs of the 12-pin standard connector. If the flat connector is being used, the address must be set through the Dip-Switch. See section 4.

#### **1.2.5 DEJAMMING FEATURE**

If motor current rise above a preset value, (see section 5.2), during normal operations, a jam is deemed to have occurred. The motor brakes, start in reverse direction and after a second brake starts again in forward direction. If the jam is not cleared, cycle is repeated.

### **1.3 SAFETY**

Do not put hands into the MINIHOPPER while functioning since it contains moving mechanical parts. The MINIHOPPER F1 PRO do not have to be installed/removed with power connected.

### **1.4 INSTALLATION**

Important: Power do not have to be applied until MINIHOPPER F1PRO's installation has been completed.

1. Fix the MINIHOPPER F1PRO through apposite screws
2. Wire up the 10-pin flat type connector or the 10-pin in line connector using pin's meaning specified in section 4.2 and 4.3 with a wire that is capable to handle maximum currents and voltages indicated in section 5.2
3. If 10-pin flat type connector is being used, select the MINIHOPPER F1PRO's address trough the DIP-Switch. See section 4.4
4. Turn on the power.

## 2 - MECHANICAL DESCRIPTION

### 2.1 GENERAL DESCRIPTION

The MINIHOPPER F1PRO is a coin and token dispenser designed to obtain the maximum maintenance simplicity.

The extraction disk used offers high reliability in coin payout even after millions of operations. MINIHOPPER F1PRO supplies more than 500 coins/minute.

### 2.2 EXPLODED DIAGRAM

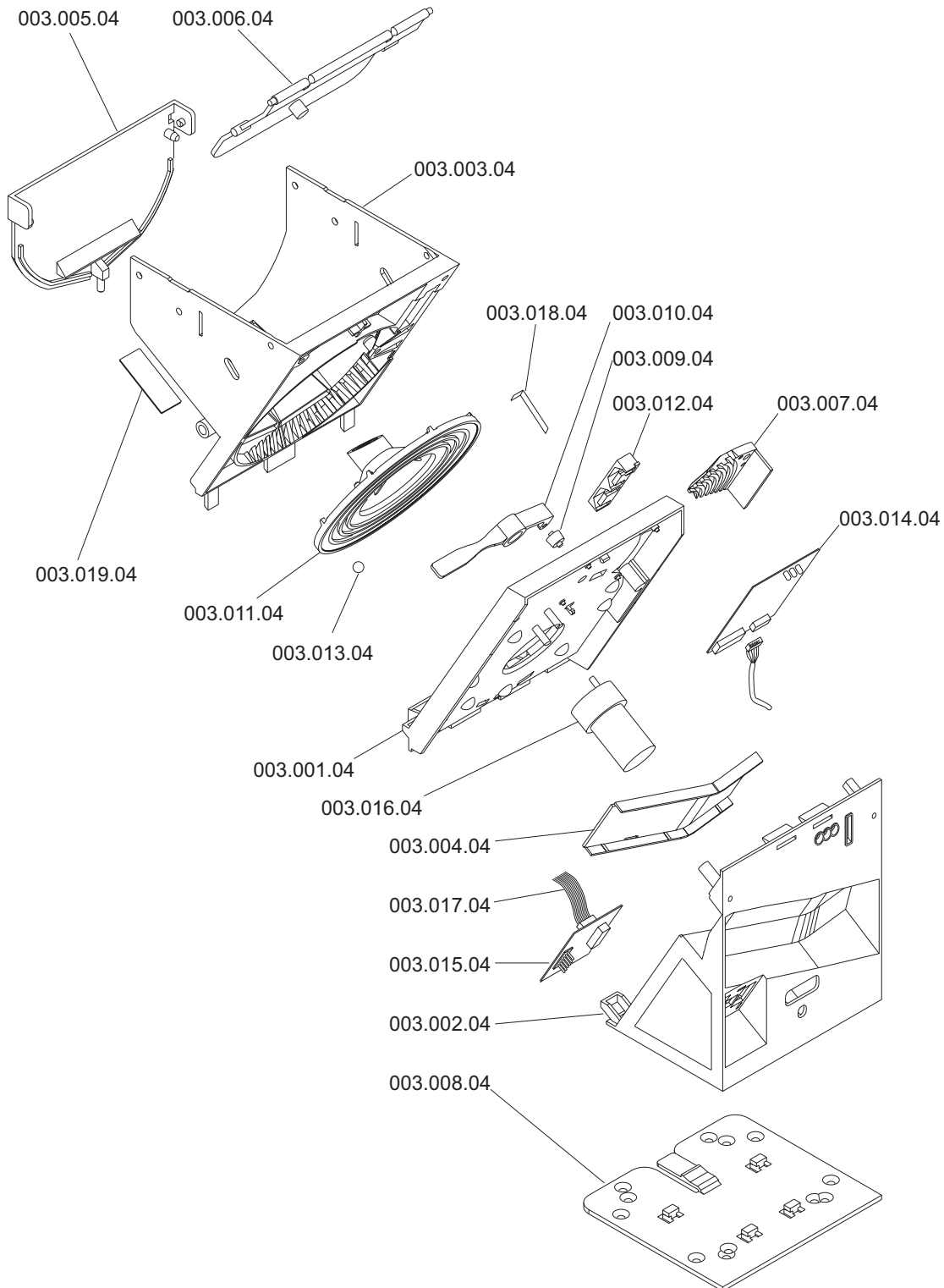

---

### **3 – ELECTRICAL DESCRIPTION**

#### **3.1 GENERAL DESCRIPTION**

The MINIHOPPER F1PRO is operated by a microcontroller that manage ccTalk communication protocol, motor's drive, optical sensors.

#### **3.2 POWER SUPPLY**

The MINIHOPPER F1PRO-1012 is powered with 12Vdc and the MINIHOPPER F1PRO-1024 is powered with 24Vdc. These voltages are provided through connectors as indicated in section 4.

#### **3.3 OPERATING MODES**

It works through the ccTalk communication protocol.

#### **3.4 OPTICAL SENSORS**

Two optical sensors are fitted in the coin exit window.  
Communication protocol ccTalk monitors all optical sensor functions through data line

#### **3.5 LED INDICATORS**

It has only one green LED that blinks quickly (once every 50ms) when logic supply is present. The blink is slower when Hopper F1PRO receive instructions on ccTalk data line.

#### **3.6 LEVEL SENSE PLATE**

Brass plates are fitted in the MINIHOPPER F1SPRO for coin level sensing.  
Signals related to sense plates are managed within ccTalk protocol.

---

## 4 - ELECTRICAL SPECIFICATION

### 4.1 INPUT/OUTPUT SIGNALS

Input/output signals used with MINIHOPPER F1PRO are considered actives when line is 0V; they work in negative logic.

Outputs are realized with open collector NPN transistors to make interfacing with other logic families like TTL, CMOS, Relay, easier.

### 4.2 FLAT CONNECTOR WITH 10-PIN

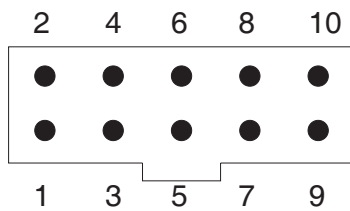

#### Connection:

<b>Pin 1</b>	: Dat ccTalk
<b>Pin 2</b>	: N.C.
<b>Pin 3</b>	: N.C.
<b>Pin 4</b>	: GND
<b>Pin 5</b>	: N.C.
<b>Pin 6</b>	: N.C.
<b>Pin 7</b>	: VCC
<b>Pin 8</b>	: GND
<b>Pin 9</b>	: N.C.
<b>Pin 10</b>	: VCC

Pins meaning is similar to the one of standard connector.

In this case the MINIHOPPER F1PRO's address selection is made through the Dip-Switch. See section 4.4

### 4.3 IN LINE CONNECTOR WITH 10-PIN

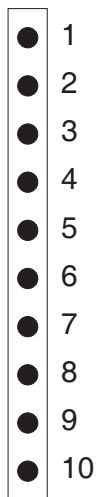

#### Connection:

<b>Pin 1</b>	: ADD 3
<b>Pin 2</b>	: ADD 2
<b>Pin 3</b>	: ADD 1
<b>Pin 4</b>	: VCC
<b>Pin 5</b>	: VCC
<b>Pin 6</b>	: GND
<b>Pin 7</b>	: GND
<b>Pin 8</b>	: Data cc Talk
<b>Pin 9</b>	: Hight level sens
<b>Pin 10</b>	: N.C.

#### 4.4 ADDRESS SELECTION

MINIHOPPER F1PRO address selection can be made through pin 1, 2, 3 of the 10-pin in line connector or alternatively through the on board DIP-Switch if the 10-pin flat type connector is being used. Possible configurations are shown in the following table:

Address			
Add.Sel 3	Add. Sel 2	Add. Sel 1	Serial Add.
			3
		ON	4
	ON		5
	ON	ON	6
ON			7
ON		ON	8
ON	ON		9
ON	ON	ON	10

#### Dip-switch

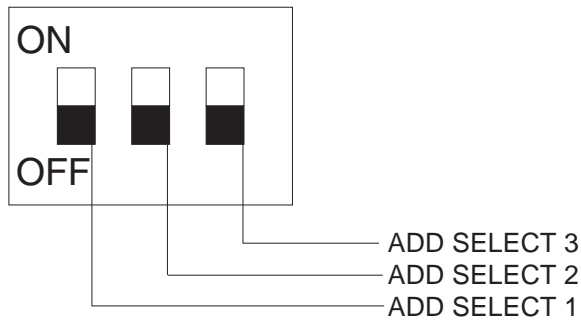

Address Select 1, Address Select 2 and Address Select 3 pins are pulled down to ground. So "ON" condition in the address signals of in line connector's pins, is obtained raising the line to Vcc.

 **The two address modality (through connector or DIP-Switch) must NOT be used at the same time because short circuits can occur.**

---

## 5 - TECHNICAL SPECIFICATION

### 5.1 COIN SIZES

The MINIHOPPER F1PRO works with coin and token in the range 17mm - 31mm diameter.

### 5.2 MOTOR AND LOGIC SUPPLY

#### MINIHOPPER F1 PRO-1012

Current consumption with 12V dc power supply ( $\pm 10\%$ )

Standby	Empty	Max load	Forced stop
50 mA	230 mA	750 mA	750 mA

#### MINIHOPPER F1 PRO-1024

Current consumption with 24V dc power supply ( $\pm 10\%$ )

Standby	Empty	Max load	Forced stop
50 mA	130 mA	500 mA	(transient) 500 mA

**Standby:** Hopper is powered but it is not working.

**Empty:** Hopper's normal functioning condition.

**Max Load:** Hopper's maximum coin load functioning condition.

**Forced Stop:** Value of current that cause a motor forced brake because motor or elevator belt is considered to be blocked. Dejamming procedure is activated.

5.3 OVERALL DIMENSIONS

